

A powerful boring machine that can be customized to suit your needs

The most powerful boring machine in its class, you'll be amazed at the power and flexibility of the BB5000 Portable Boring Machine.

Exclusive, CLIMAX-patented mounting components provide the flexibility to handle tough boring jobs, even when used in cramped, tight workspaces.

Quick and Easy Setup

- Modular components make setup quick and easy.
- Fast and easy setup using high quality cast-iron set-up cones and spherical bearing mounts.
- Patented spherical bearing mounting system allows quick setup, with up to 5° of bearing misalignment.
- Typical set-up time for an experienced operator is 30 minutes or less.

Powerful

- Up to 650 ft-lbs (881 N·m) of torque at the bar – more than any other portable boring machine in its boring range.
- Specially-designed rotational drive unit provides 4:1 or optional 12:1 or worm gear reduction for increased torque at all speeds

Flexible, High Quality Design

- Through-bar design allows the rotational drive and feed unit to be mounted anywhere along the bar, even separately.
- Patented heavy-duty spherical bearing mounts ensure rigid attachment to the work piece, for more effective machining.



Versatile

- Highly customizable to meet a variety of needs.
- Available in electric, servo, hydraulic, or pneumatic motor configurations.
- Reversible electric motor.
- Fast, easy two-bolt change-out process to switch motors.
- Available in a variety of bar lengths, from 4 - 24 feet (1219.2 – 7315.2 mm).
- Bars are straightened, and have ½ inch or 12 mm square-broached tooling holes.

- Accessories allow the BB5000 to be used for blind boring, line boring, drilling, facing, and valve repair.

- An interface kit allows attachment and quick alignment of the CLIMAX Auto Bore Welders for efficient bore welding.

Compact

- Extremely compact for ease of use in cramped, tight work spaces.
- Drive & Feed can be mounted between bearings for use in even more confined spaces.

	US	Metric
Operating Ranges:		
Boring Bar Diameter		
Standard	2.25 inches	57.2 mm
Optional	1.75 inches	44.5 mm
Optional	1.25 inches	31.8 mm
Boring Diameter		
Standard	2.5 - 12 inches	63.5 - 304.8 mm
Optional	1.375 - 24 inches	34.9 - 609.6 mm
Boring Stroke		
	12, 24, or 36 inches	304.8, 609.6, or 914.4 mm
Power Options		
Electric: 8 to 160 free speed bar RPM	3.35 Hp	2.5 kW
Servo: up to 230 free speed bar RPM	4.7 Hp	3.5 kW
Hydraulic: 10 Hp HPU	10 Hp	7.5 kW
- 240 free speed bar RPM with 60 Hz mains power		
- 200 free speed bar RPM with 50 Hz mains power		
Pneumatic: up to 120 bar free speed RPM	3.0 Hp	2.2 kW
Mounting Options		
	Single Arm, Double Arm, Universal, ID	
Rotational Drive Unit		
	4:1 gear ratio reduction Option 12:1 gear ratio reduction	
Set-Up Cones		
Standard	2.75 - 12 inches	70.0 – 304.8 mm
Optional	1.375 - 5 inches	34.9 – 127.0 mm
Feed		
	Mechanical	Mechanical
Feed Rate per revolution (Infinitely variable and reversible)		
	0 – 0.018 inches/rev.	0 – 0.46 mm/rev.
Measures		
Typical Machine Ship Weight (Typical machine with single arm mounts, set-up cones & hydraulic motor)		
	444 lbs	201 kg
Approximate Boring Bar Ship Weight (Includes metal shipping container)		
	1.48 lbs/inch	0.264 kg/cm
Shipping Dimensions (Shipped in 2 containers, 3 containers for hydraulic power unit option.)		
Machine W, D, H	52.5 x 27 x 16.5 inches	1334 x 686 x 419 mm
Bar 72 inch (1828.8 mm) W, D, H	74.5 x 6.5 x 7 inches	1892 x 165 x 178 mm
HPU [5 or 10 Hp] W, D, H	49.5 x 30.5 x 41 inches	1257 x 775 x 1041 mm

All dimensions should be considered reference. Contact your CLIMAX Representative for precision dimensions. Specifications are subject to change without notice. There are no systems or components on this machine that are capable of producing hazardous EMC, UV or other radiation hazards. The machine does not use lasers nor does it create hazardous materials such as gasses or dust.

A Fast Six-Step Process

Setup of the BB5000 Portable Boring Machine is quick and easy. An experienced operator can set up the machine in most typical two-bore line boring applications in about half an hour (depending on alignment tolerances). The three main ingredients of the quick setup system are:

- Setup cones to roughly center the bar in the bore.
- Spherical mounts that can be quickly tack-welded in place.
- Quick-mount rotational drive unit, attaches to spherical mount in seconds

1 Slide the bar through the two holes to be bored and roughly center it with the set-up cones. The set-up cones are forced into the bore with the clamp ring jacking screw and locked onto the bar with a set screw.

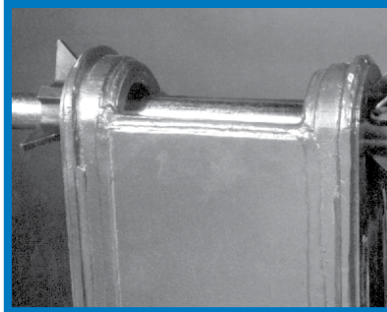

Elapsed time: 4 minutes.

4 Slide the rotational drive onto the bar. Firmly push it onto the spherical mount, and lock it in place with one bolt. Tighten the rear clamping collar enough to be snug but so the bar can slide through it.



Elapsed time: 4 minutes.

2 Slide on spherical mounts with tack weld plates, and tack weld them to the workpiece. These mounts have spherical bearings so they can be mounted up to 5° out of perpendicular alignment.

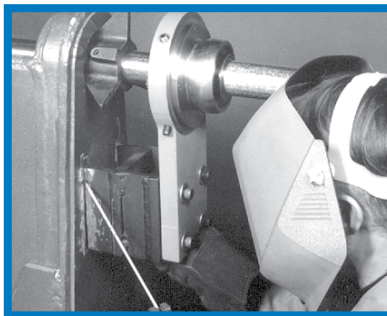

Elapsed time: 10 minutes.

5 The axial feed unit is slipped onto the bar and the leadscrew is screwed into the pocket on the rotational drive unit. Tightening two clamping collars locks the axial feed unit to the bar.

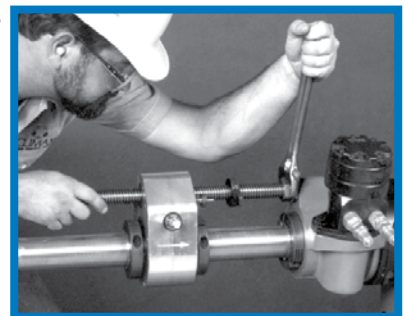

Elapsed time: 3 minutes.

3 Remove the set-up cones and replace the bar. The set-up cones will adequately center the bar, unless you have very precise tolerances, or need to move the centerline of the bore slightly. Final centering adjustments are made with the jacking screws.



Elapsed time: 5 minutes.

6 Insert a properly ground tool bit into the tool hole in the bar, adjust for depth of cut, and lock in place with the set screw. Connect to power source. Elapsed time: 5 minutes.

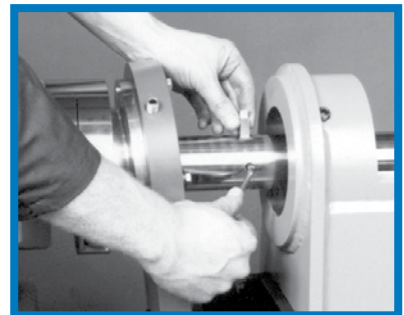

And there you are... ready to begin the first boring pass.

Total elapsed time: 31 minutes.

Dimensions in Inch (mm)

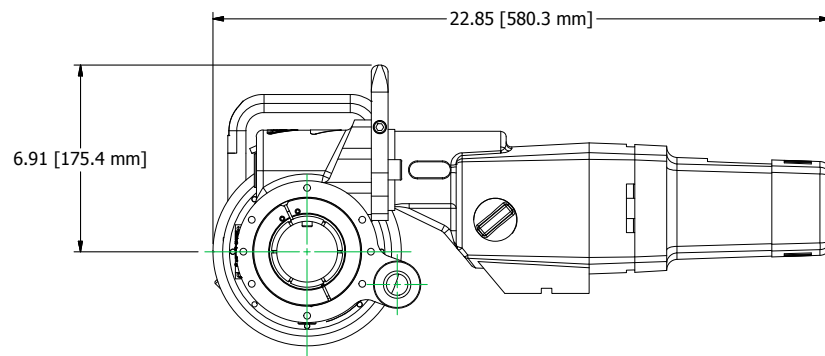
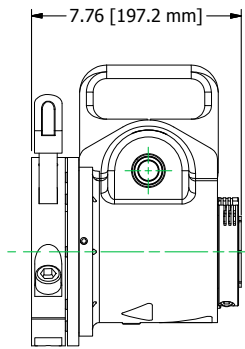

Rotational drive unit with electric motor

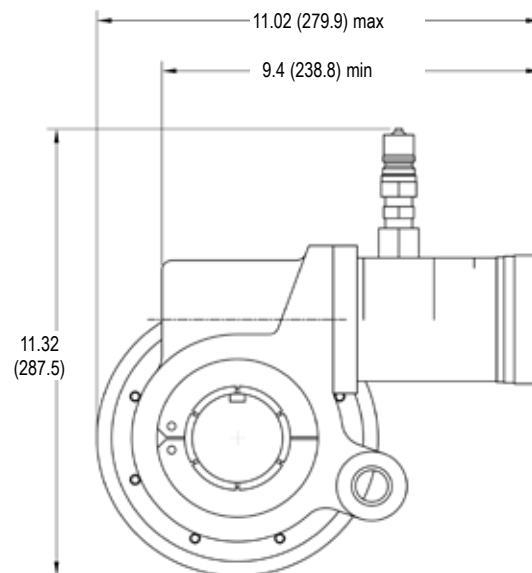

Rotational drive unit with hydraulic motor

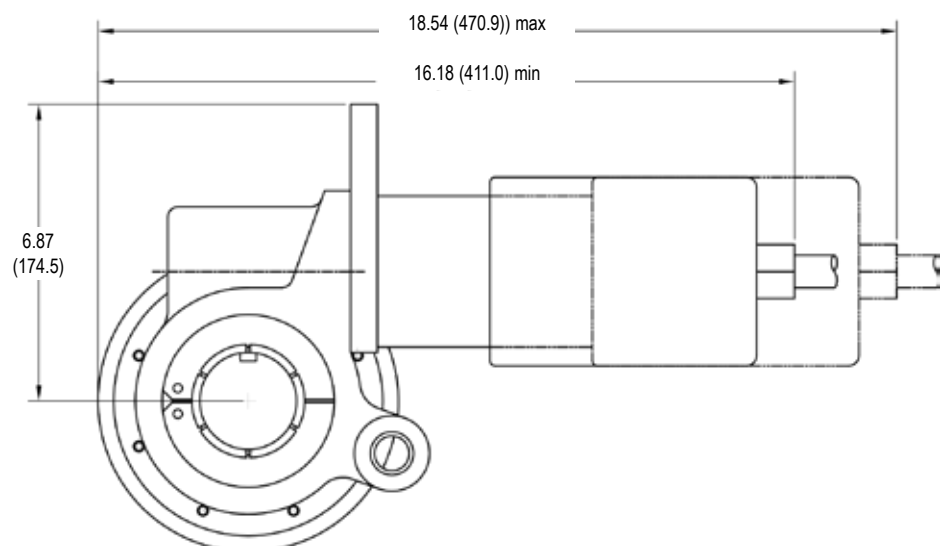

Rotational drive unit with pneumatic motor

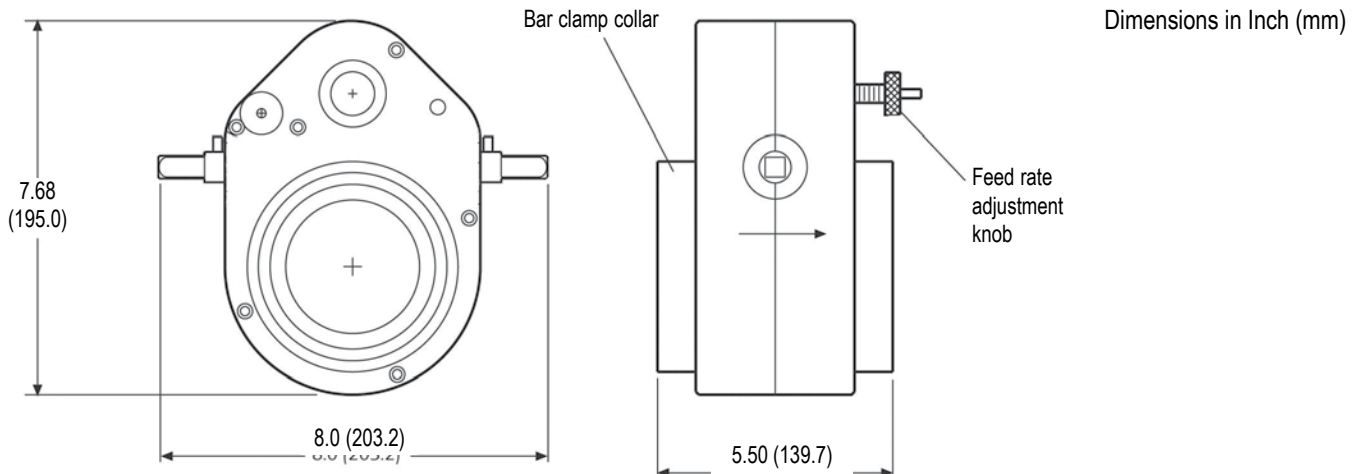

Axial feed unit

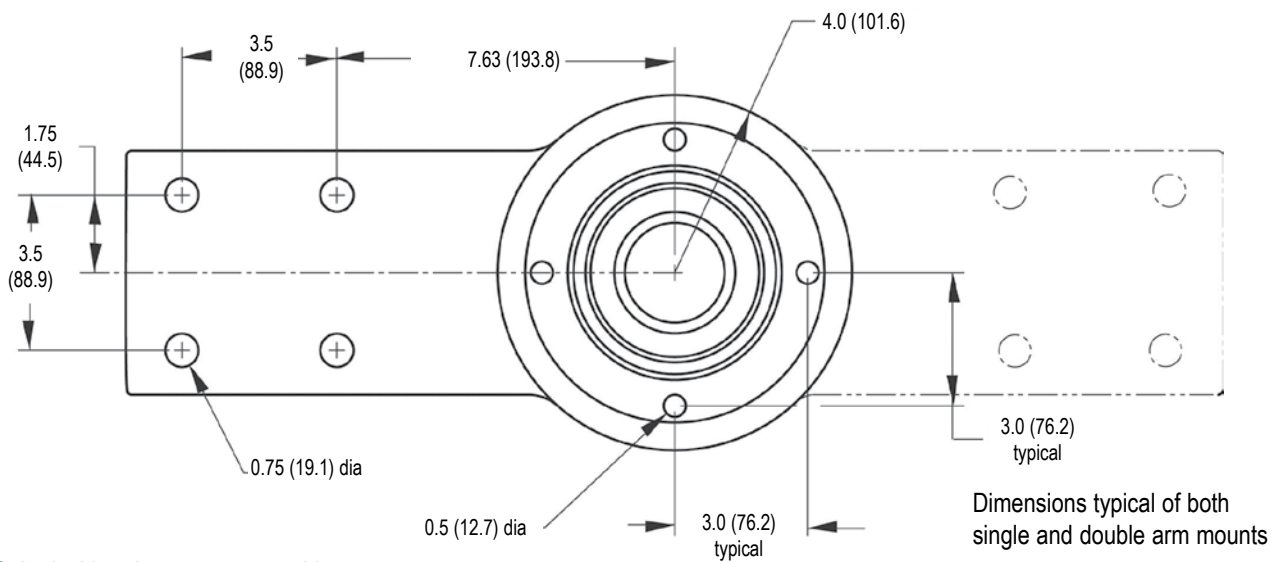

Spherical bearing mount assembly

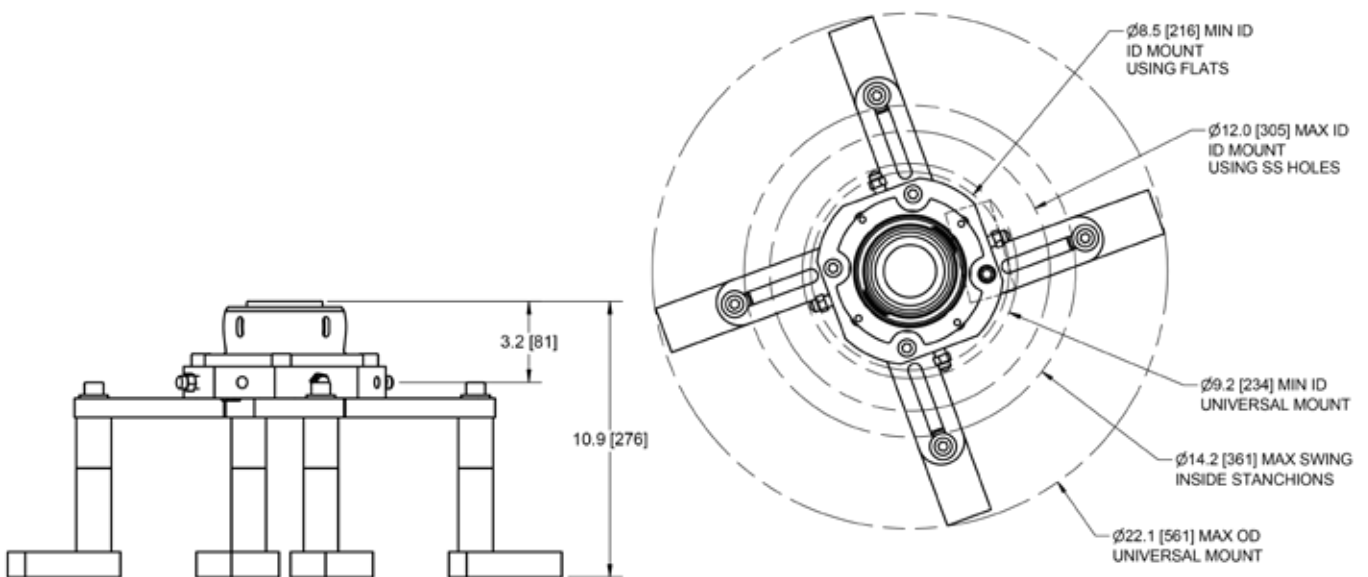

Universal bearing mount assembly

Reach can be extended an additional 12 inches (304.8 mm) using extension arms.

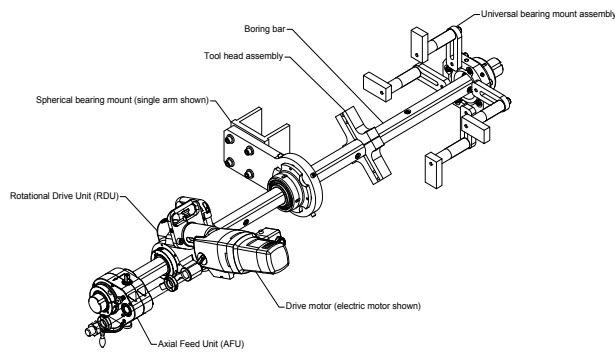

Configure your BB5000 in 8 easy steps:

1. Select a Base Unit
2. Select a Boring Bar
3. Select a Drive Motor Option
4. Select a Speed Control
5. Select a Leadscrew
6. Select Setup Cones
7. Select a Mounting Option
8. Select Optional Small Bore Kit

To generate the correct part number for the boring machine you require, simply select the part number needed in each step, and contact your CLIMAX representative.

1. Base Unit

(Includes RDU, AFU, Tool Heads, Tool Kit, Operator's Manual and Compartmentalized Metal Container)

Inch Base Unit, 4:1 RDU	49003
Metric Base Unit, 4:1 RDU	49004
Inch Base Unit, 12:1 RDU for Servo	54499
Metric Base Unit, 12:1 RDU for Servo	54501

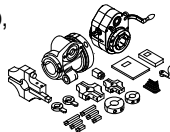

2. Boring Bar (Inch)

Bars are 2-1/4 inch diameter, chrome-plated steel with full length keyway.

48 inch bar, 1/2 inch tooling holes every 6 inches	39309
72 inch bar, 1/2 inch tooling holes every 6 inches	39310
96 inch bar, 1/2 inch tooling holes every 6 inches	41552
120 inch bar, 1/2 inch tooling holes every 6 inches	43728
144 inch bar, 1/2 inch tooling holes every 6 inches	43729
48 inch bar, 1/2 inch tooling holes every 10 inches	34626
72 inch bar, 1/2 inch tooling holes every 10 inches	34627
96 inch bar, 1/2 inch tooling holes every 10 inches	34628
120 inch bar, 1/2 inch tooling holes every 10 inches	34629
144 inch bar, 1/2 inch tooling holes every 10 inches	34630

*Multiple units may be ordered.

Boring Bar (Metric)

Bars are 2-1/4 inch diameter, chrome-plated steel with full length keyway.

1219.2 mm bar, 12 mm tooling holes every 152.4 mm	43740
1828.8 mm bar, 12 mm tooling holes every 152.4 mm	43741
2438.4 mm bar, 12 mm tooling holes every 152.4 mm	43742
3048.0 mm bar, 12 mm tooling holes every 152.4 mm	43743
3657.6 mm bar, 12 mm tooling holes every 152.4 mm	43744
1219.2 mm bar, 12 mm tooling holes every 254.0 mm	34635
1828.8 mm bar, 12 mm tooling holes every 254.0 mm	34636
2438.4 mm bar, 12 mm tooling holes every 254.0 mm	34637
3048.0 mm bar, 12 mm tooling holes every 254.0 mm	34638
3657.6 mm bar, 12 mm tooling holes every 254.0 mm	34639

*Multiple units may be ordered.

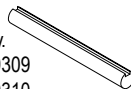

3. Drive Motor

Electric:

120 VAC, 50/60 Hz, 8/160 bar rpm, 4 speed reversible, CE 88008
 230 VAC, 50/60 Hz, 8/160 bar rpm, 4 speed reversible, CE 88009

Servo Electric

230V (12:1 RDU), CE 56026
 230V (12:1 RDU), non-CE 71071
 460V (12:1 RDU), CE 56027
 460V (12:1 RDU), non-CE 71072

Hydraulic:

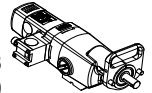

Motor Capacity		Max Bar RPM at		Torque at Bar Calculated ft-lbs, (N·m)	Part No. Motors with 60 Series QD Fittings	Part No. Motors with ISO 16028 QD Fittings
In ³	cm ³	8.3 gpm (31.5 L/min) with 50 Hz mains power	10 gpm (37.9 L/min) with 60 Hz mains power			
2.2	36	204	246	92 (124.7)	39837	65384
3.6	59	124	150	159 (215.6)	39843	63425
5.7	93.4	76	92	270 (367)	39844	63429
7.3	119.6	60	73	342 (463.7)	39845	69434
8.9	145.8	49	60	417 (565.4)	39846	69435
11.3	185.2	40	49	478 (648.1)	43451	69436
14.1	231.1	31	38	652 (884.0)	39847	69438
17.9	293.3	24	30	764 (1035.8)	43452	69439

Minimum speed is 20% of the maximum speed

Pneumatic (3 Hp (2.2 kW) includes pneumatic conditioning unit):

57 rpm 234 ft-lbs (317.3 N·m) non-CE 37498
 120 rpm 115 ft-lbs (155.9 N·m) non-CE 39112
 * Multiple units may be ordered.



4. Controller (all are CE compliant)

120V Controller, NEMA L5-30P ** 88037
 120V Controller, ISO 309/CEE 17 ** 88038
 230V Controller, CEE 7/7 SCHUKO ** 88035
 230V Controller, NEMA L6-15P ** 88036

**If a different type of electrical plug is required, the end user must replace these standard plugs in the field.



5. Leadscrew

12 inch (304.8 mm) leadscrew 28654
 24 inch (609.6 mm) leadscrew 28687
 36 inch (914.4 mm) leadscrew 28688
 * Multiple units may be ordered



6. Setup Cones (cast iron, for 2-1/4 inch dia. bars)

Small setup cones (2.75 - 8.37 inches) 26507
 Large setup cones (8.37 - 12 inches) 26508
 Full set of setup cones (2.75 - 12 inches) 26383



7. Mounting Option

Single arm mount (1) (for 2-1/4 inch dia. bars) 37472
 Double arm mount (1) (for 2-1/4 inch dia. bars) 37473
 Universal mount (1) (for 2-1/4 inch dia. bars) 36959
 ID mount (1) (for 2-1/4 inch dia. bars) 46293
 * Multiple units may be ordered.

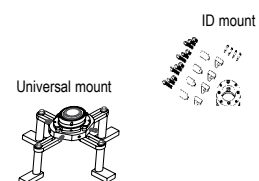
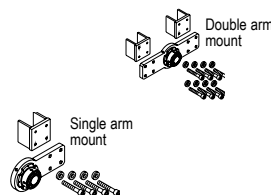

NOTE: Drawings are for reference only, are not to scale, and may not represent actual product.

8. Optional Small Bore Components

If selecting Small Bore components, please select from the following. Bars selected separately.

AFU & RDU Collets & Drive Key

Collets for 1- $\frac{1}{4}$ inch bar (inch)	48999
Collets for 1- $\frac{1}{4}$ inch bar (metric)	49000
Collets for 1- $\frac{3}{4}$ inch bar (inch)	49001
Collets for 1- $\frac{3}{4}$ inch bar (metric)	49002



1- $\frac{1}{4}$ inch Boring Bar for Kit (inch)

36 inch bar, $\frac{3}{8}$ inch tooling holes every 6 inches	40925
48 inch bar, $\frac{3}{8}$ inch tooling holes every 6 inches	39308
72 inch bar, $\frac{3}{8}$ inch tooling holes every 6 inches	43693
96 inch bar, $\frac{3}{8}$ inch tooling holes every 6 inches	39447
48 inch bar, $\frac{3}{8}$ inch tooling holes every 10 inches	37337
72 inch bar, $\frac{3}{8}$ inch tooling holes every 10 inches	37338
96 inch bar, $\frac{3}{8}$ inch tooling holes every 10 inches	37339
120 inch bar, $\frac{3}{8}$ inch tooling holes every 10 inches	37340
144 inch bar, $\frac{3}{8}$ inch tooling holes every 10 inches	37341

* Multiple units may be ordered.

1- $\frac{1}{4}$ inch Boring Bar for Kit (metric)

914.4 mm bar, 10 mm tooling holes every 152.4 mm	43688
1219.2 mm bar, 10 mm tooling holes every 152.4 mm	43687
1828.8 mm bar, 10 mm tooling holes every 152.4 mm	43686
2438.4 mm bar, 10 mm tooling holes every 152.4 mm	43685
1219.2 mm bar, 10 mm tooling holes every 254.0 mm	37327
1828.8 mm bar, 10 mm tooling holes every 254.0 mm	37328
2438.4 mm bar, 10 mm tooling holes every 254.0 mm	37329
3048.0 mm bar, 10 mm tooling holes every 254.0 mm	37330
3657.6 mm bar, 10 mm tooling holes every 254.0 mm	37331

* Multiple units may be ordered.

1- $\frac{3}{4}$ inch Boring Bar for Kit (inch)

36 inch bar, $\frac{1}{2}$ inch tooling holes every 6 inches	43288
48 inch bar, $\frac{1}{2}$ inch tooling holes every 6 inches	43311
60 inch bar, $\frac{1}{2}$ inch tooling holes every 6 inches	43312
72 inch bar, $\frac{1}{2}$ inch tooling holes every 6 inches	43313
96 inch bar, $\frac{1}{2}$ inch tooling holes every 6 inches	43314
48 inch bar, $\frac{1}{2}$ inch tooling holes every 10 inches	43318
60 inch bar, $\frac{1}{2}$ inch tooling holes every 10 inches	43319
72 inch bar, $\frac{1}{2}$ inch tooling holes every 10 inches	43320
96 inch bar, $\frac{1}{2}$ inch tooling holes every 10 inches	43321
120 inch bar, $\frac{1}{2}$ inch tooling holes every 10 inches	43322
144 inch bar, $\frac{1}{2}$ inch tooling holes every 10 inches	43323

* Multiple units may be ordered.

1- $\frac{3}{4}$ inch Boring Bar for Kit (metric)

914.4 mm bar, 12 mm tooling holes every 152.4 mm	43297
1219.2 mm bar, 12 mm tooling holes every 152.4 mm	43298
1524.0 mm bar, 12 mm tooling holes every 152.4 mm	43299
1828.8 mm bar, 12 mm tooling holes every 152.4 mm	43300
2438.4 mm bar, 12 mm tooling holes every 152.4 mm	43301
1219.2 mm bar, 12 mm tooling holes every 254.0 mm	43305
1828.8 mm bar, 12 mm tooling holes every 254.0 mm	43306
1524.0 mm bar, 12 mm tooling holes every 254.0 mm	43307
2438.4 mm bar, 12 mm tooling holes every 254.0 mm	43308
3048.0 mm bar, 12 mm tooling holes every 254.0 mm	43309
3657.6 mm bar, 12 mm tooling holes every 254.0 mm	43310

* Multiple units may be ordered.

$\frac{3}{8}$ inch Tooling Kits (for 1- $\frac{1}{4}$ inch bars)

HSS 0 degree and 15 degree lead angles (3 lengths) 0.98, 1.3 and 1.8 inches	37502
HSS 15 degree lead angle (3 lengths) 1.3, 1.8 and 2.2 inches	49008
Cemented carbide 0 and 15 degree lead angle	49009
Cemented carbide 15 degree lead angle (3 lengths) 1.3, 1.8 and 2.2 inches	49010

10 mm Tooling Kits

HSS 0 degree and 15 degree lead angles (3 lengths) 25, 33 and 46 mm	49011
HSS 15 degree lead angle (3 lengths) 25, 33 and 46 mm	49012

Small Bore Kit Bearing Collets

1- $\frac{1}{4}$ inch (31.8 mm) bearing collet (each)	26719
1- $\frac{3}{4}$ inch (44.5 mm) bearing collet (each)	26722



Small Bore Kit Setup Cones

For 1- $\frac{1}{2}$ to 3- $\frac{1}{4}$ inch (38.1 to 82.6 mm) - aluminum	26263
For 1- $\frac{3}{4}$ inch (44.5 mm) bar - cast iron	43383

ACCESSORIES

Small Bore Components for Your BB5000:

Small Bore Kits Without Bars

60654	1- $\frac{1}{4}$ inch diameter small bore kit includes the following: 48999 RDU collet with drive key, AFU collet 26719 (4) bearing collets 26263 set of aluminum set up cones
60630	1- $\frac{1}{4}$ inch diameter small bore kit includes the following: 48999 RDU drive collet with drive key, AFU collet 26719 (4) bearing collets 26263 set of aluminum set up cones 26656 1- $\frac{1}{4}$ inch alignment tool for BoreWelder
63933	1- $\frac{3}{4}$ inch diameter small bore kit includes: 49001 RDU collet with drive key & AFU collet 26722 (4) bearing collets 43383 Small cast iron set up cones for 1- $\frac{3}{4}$ inch bar
63934	1- $\frac{3}{4}$ inch diameter small bore kit includes: 49001 RDU collet with drive key & AFU collet 26722 (4) bearing collets 43383 Small cast iron set up cones for 1- $\frac{3}{4}$ inch bar 36062 1- $\frac{3}{4}$ inch alignment tool for BoreWelder

Sleeve Sets

Include rotational drive collet with drive key, axial feed collet, and two bearing collets every bearing requires a collet). All collets include retaining snap rings.



28698	1- $\frac{1}{4}$ inch (31.8 mm) diameter small bore collet set (for use with 2- $\frac{1}{4}$ inch (57.2 mm) diameter components. RDU collet with drive key, AFU collet, (2) bearing collet.
44614	1- $\frac{1}{4}$ inch (31.8 mm) diameter small bore collet set (for use with 2 inch (50.8 mm) diameter components.) RDU collet with drive key, AFU collet, (2) bearing collet
44091	1- $\frac{3}{4}$ inch (44.5 mm) diameter small bore collet set (for use with 2- $\frac{1}{4}$ inch (57.2 mm) diameter components) RDU collet with drive key, AFU collet, (2) bearing collet

Other Small Bore Components

26263	Set of (2) aluminum set-up cones, 1.5 - 3.25 inch (38.1 - 82.6 mm) diameter, for 1-$\frac{1}{4}$ inch (44.5 mm) diameter bar
43383	Set of (2) cast iron set-up cones, 2.0 - 6.0 inch (50.8 - 152.4 mm) diameter, for 1-$\frac{3}{4}$ inch (31.8 mm) diameter bar
26719	(2) bearing collets for 1-$\frac{1}{4}$ inch inch dia. bar
26722	(2) bearing collets for 1-$\frac{3}{4}$ inch dia. bar
26728	snap ring for 2- $\frac{1}{4}$ inch (57.2 mm) diameter components
31612	Snap ring for 2 inch (50.8 mm) diameter components
28699	RDU collet with key for 1- $\frac{1}{4}$ inch diameter bar
28989	RDU collet with key for 1- $\frac{3}{4}$ inch diameter bar
36317	RDU collet for 2 inch diameter bar
26720	AFU collet for 1- $\frac{1}{4}$ inch diameter bar
26723	AFU collet for 1- $\frac{3}{4}$ inch diameter bar
36312	AFU collet for 2 inch diameter bar

Configurations shown represent standard options. Please contact us for special fixturing, CNC Control options, or other features that may be needed for your specific machining application. We look forward to working with you!

No. Description

Automated Bore Welders

Add an Automated Bore Welder to your BB5000 Boring Machine with the convenient bore welder interface kit. Attach the bore welder to the BB5000's mounting fixture to ensure perfect alignment for both welding and machining. A single setup for both welding and machining saves time, and helps get the job done quickly. (All bore welders include welding head, torches, mounting rod & radial mount, torch extensions, conduit switch assembly, tips, nozzles, diffuser, and liner. See table below to compare other features & components.)

BoreWelding Interface Kit (See the CLIMAX BoreWelder product literature for details)

- 26518** Complete interface kit for 2-¼ inch (57.2 mm) diameter bar.
- 36062** Alignment tool only for 1-¾ inch (44.5 mm) diameter bar.
- 26656** Alignment tool only for 1-¼ inch (31.8 mm) diameter bar.

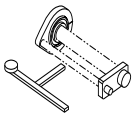

BW1000 AutoBoreWelder

BW3000 AutoBoreWelder

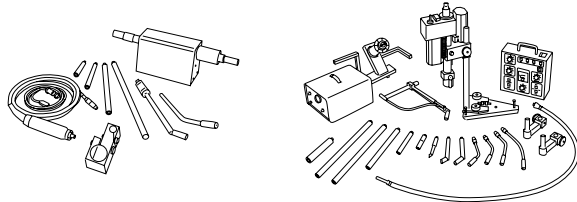

Model	Welding Dia. Inch (mm)	Facing Torch Option	Wire Feeder Included	Auto-Skip Included
BW1000	0.88 - 12.0 (22.4 - 304.8)	No	No	No
BW3000	0.88 - 13.0 (22.4 - 330.2)	Yes	Yes	Yes

Mechanical Axial Feed Assembly

Mounts anywhere on the bar. Reversible ratchet feed mechanism has variable feed rate up to 0.19 inches (0.48 mm) per revolution. Feeds the tool and bar by moving along the stationary leadscrew. Adjustable clamp collars on both ends clamp unit to the bar. Includes auto stop.

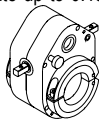

The **Heavy Duty AFU** is designed with an adjusting shaft and a heavy duty feed adjustment knob to reduce damage from handling. The integral roller bearing clutches allow the feed clutches to last longer, while the heavier springs and minimal mass cam arms allow the system to work at higher speeds, similar to the servo powered RDU.

- 28636** Standard AFU for 2-¼ inch (57.2 mm) diameter bar.
- 91518** Heavy Duty AFU for 2-¼ inch (57.2 mm) diameter bar
- 29908** Standard AFU for 2.0 inch (50.8 mm) diameter bar

Rotational Drive Assembly

Mounts anywhere on the bar. Features heavy-duty cast aluminum housing, Timken roller bearings, and sealed, lifetime lubrication. Clamp ring mounts assembly to spherical bearings with one bolt.



Part Number.	Generation	Worm Gear Reduction	Accepts Bar Dia.	Key Size
49684	4th	4:1	2-¼ inch	⅜ inch
29910	3rd	4:1	2 inch	¼ inch
65620	4th	4:1	2 inch	¼ inch
34028	3rd	4:1	2 inch	8 mm
65678	4th	4:1	2 inch	8 mm
53165	4th	12:1	2-¼ inch	⅜ inch

No. Description

Electric Motor Assembly

Assembly includes four-speed variable electric motor and mounting flange.



- 88008** 120 VAC, 50/60 Hz, 8/160 bar rpm, 4 speed reversible, CE.
- 88009** 230 VAC, 50/60 Hz, 8/160 bar rpm, 4 speed reversible, CE

Control Box

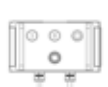

- 88037** 120V Controller, NEMA L5-30P **
- 88038** 120V Controller, 150 309/CEE 17 **
- 88035** 230V Controller, CEE 7/7 SCHUKO **
- 88036** 230V Controller, NEMA L6-15P **

**If a different type of electrical plug is required, the end user must replace these standard plugs in the field.



Electric Servo Motor Assembly

Compact, lightweight servo drive system provides 3 - 230 RPM of variable speed and up to 443.7 ft-lbs (601.2 N•m) of torque at the bar, providing the power of a hydraulic power unit in a ultra quiet, quick to set up package. Includes 12:1 RDU.

- 54321** Electric servo motor, 230V, CE compliant
- 52876** Electric servo motor, 460V, CE compliant

Hydraulic Motor Assembly

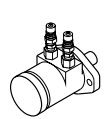

Reversible hydraulic motor and SAE 2-bolt mounting flange to mount to the rotational drive housing. Motor ports are 7/8 - 14 SAE O-ring type. ½ inch dripless quick-connect fitting kit installed. Bar rpm's are max at 6 gpm (22.7 L/min). (For 50 Hz power units, reduce the bar rpm by 15%; bar torque remains the same.) Also available with 3/8 inch (9.5 mm) fitting kits.

Motor Capacity		Max Bar RPM at		Torque at Bar, - Calculated - ft-lbs, (N•m)	Part No. Motors with 60 Series QD Fittings	Part No. Motors with ISO 16028 QD Fittings
in ³	cm ³	8.3 gpm (31.5 L/min) with 50 Hz mains power	10 gpm (37.9 L/min) with 60 Hz mains power			
2.2	36	204	246	92 (124.7)	39837	65384
3.6	59	124	150	159 (215.6)	39843	63425
5.7	93.4	76	92	270 (367)	39844	63429
7.3	119.6	60	73	342 (463.7)	39845	69434
8.9	145.8	49	60	417 (565.4)	39846	69435
11.3	185.2	40	49	478 (648.1)	43451	69436
14.1	231.1	31	38	652 (884.0)	39847	69438
17.9	293.3	24	30	764 (1035.8)	43452	69439

Minimum speed is 20% of the maximum speed

Hydraulic Power Unit

10 Hp (7.5 kW) 10 gpm (37.9 L/min) units with 3-phase electric motor, with variable displacement pump, allow speed control without sacrificing torque. **Many models available. Please ask a CLIMAX representative for details.**

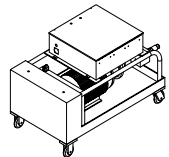

Pneumatic motor assembly

The 3 Hp (2.2 kW) motor comes complete, ready for 2-bolt mounting directly on the rotational drive. Does not include pneumatic conditioning unit.



Part Number.	Max Bar RPM	Torque at the bar (calculated value)
28614 (CE)	120 rpm	115 ft-lb (155.9 N•m)
28697 (CE)	57 rpm	234 ft-lb (317.3 N•m)

NOTE: Drawings are for reference only, are not to scale, and may not represent actual product.

No. Description

Axial leadscrew assembly

Stationary leadscrew assembly is fixed in position by screwing it into the rotational drive assembly or into tack weld mounting block. Acme nut holds leadscrew in place. Includes leadscrew and two Acme nuts.

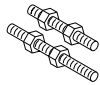

Leadscrews available in lengths below. Other lengths available by request.

- 28654 12 inch (304.8 mm) travel
- 28687 24 inch (609.6 mm) travel
- 28688 36 inch (914.4 mm) travel
- 39335 48 inch (1219.2 mm) travel
- 28756 Leadscrew tack weld block

Set-up cones

Cones slide onto the bar and into fairly round, in-line holes for fast set-up. Set screws and back-up clamp collars hold the cones in place while the components are being attached.



- 26263 Set of 2 aluminum set-up cones, 1.5 - 3.25 inch (38.1 - 82.6 mm) bore ID. **Fit 1-1/4 inch (31.8 mm) diameter bars.**
- 26507 Set of 2 cast iron set-up cones for 2.75 - 8.37 inch (69.9 - 212.6 mm) bore ID. **Fit 2-1/4 inch (57.2 mm) diameter bars.**
- 26508 Set of 2 cast iron set-up cones for 8.37 - 12 inch (212.6 - 304.8 mm) bore ID. **Fit 2-1/4 inch (57.2 mm) diameter bars.**
- 26383 Full set of cast iron set-up cones for 2.75 - 12 inch (69.9 - 304.8 mm) bore ID. **Fit 2-1/4 inch (57.2 mm) diameter bars.**
- 31801 Set of 2 cast iron set-up cones for 2.75 - 8.37 inch (69.9 - 212.6 mm) bore ID. **Fit 2 inch (50.8 mm) diameter bars.**
- 31802 Set of 2 cast iron set-up cones for 8.37 - 12 inch (212.6 - 304.8 mm) bore ID. **Fit 2 inch (50.8 mm) diameter bars.**

Spherical bearing mounts

Available in single arm, double arm, and universal mount styles, our spherical bearing mounts attach directly to the work piece, and accept both the model BB5000 rotational drive, and the mounting bracket for the CLIMAX AutoBoreWelders. (Includes bracket, bearing, and hardware.)

Single arm bearing mount

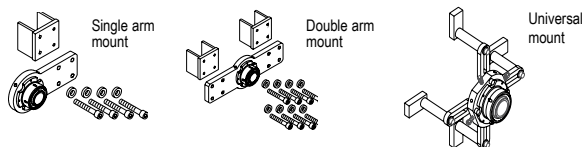

- 37472 for 2-1/4 inch (57.2 mm) bars
- 36710 for 2 inch (50.8 mm) bars

Double arm

- 37473 for 2-1/4 inch (57.2 mm) bars
- 29953 for 2 inch (50.8 mm) bars

Universal

- 36959 for 2-1/4 inch (57.2 mm) bars
- 63535 Universal arm 24 inch (609.6 mm) extension kit
- 37626 ID Mount, for 8.6 - 11.2 inch (218.4 - 284.5 mm) diameter.
- 37621 Universal mount ID conversion kit

Spherical bearing

- 26248 Spherical Bearing - 2-1/4 inch (57.2 mm). Bearing mounts to bracket to align the bar.
- 29951 Spherical Bearing - 2 inch (50.8 mm). Same as above, but for 2.0 inch (50.8 mm) diameter. Order mounting hardware separately.



Face-adjustable ID bearing mount

- 46293 Ideal for mounting the BB5000 in deep or blind bores, this ID bearing mount provides an ID mounting range of 5.75 - 12.5 inches (146.1 - 317.5 mm). Easily install and adjust the mount from the open face part of your bore. Independently adjustable mounting legs also simplify centering the mount in bores which are not perfectly round.
- 46227 1.5 inch extension jaw to extend reach (need 4)



No. Description

ID mount self-aligning bearing support assembly

20319 Bearing support assembly provides 4-way adjustable bar alignment. Fits bores with ID's from 11.5 - 24 inches (292.1 - 609.6 mm). Bar is held in place by a self-aligning bearing. Assembly includes chuck and bearing, three sets of jaws, two sets of jacking screws, and one set of 1 inch (25.4 mm) spacers.



Cantilever mounting assembly

28799 Cantilever standoff mounts between two bearing mounting brackets to ensure machine rigidity when blind boring, trepanning, spade drilling, or tapping. Order bearing mounting brackets separately. Order two assemblies when using a double arm mount.



Accessories for Drilling and Blind Hole Boring

Turn your BB5000 into a powerful drilling system with the following accessories. A wide array of options available, please talk to us about your needs - we can customize a package to fit your specific need.

57140 Drill Base

Includes drill stand with grip tight bearing, tack weld spacers and all hardware. Customer will need to order #4 or #5 Morse Taper or straight shank bar (1), single arm bearing mount and drill tooling as well as BB5000 drive and feed to make a complete drill package

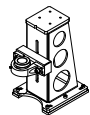

Morse Taper and Straight shank bars

CLIMAX sells special bars for drilling and blind hole boring. Options include #4 and #5 Morse Taper and bars with Morse Taper on one end and 1.25" straight shank on the opposite end. For most applications we recommend the #4 Morse Taper. The majority of our drilling and blind hole boring tooling is supplied with #4 Morse Taper.



2-1/4 Inch (57.2 mm) diameter Bars for Drilling and Blind Hole Boring				
Bar Length Inch (mm)	#4 Morse Taper only	#4 Morse Taper and straight Shank	#5 Morse Taper only	#5 Morse Taper and Straight Shank
24 (609.6)	58828		19282	18715
36 (914.4)	36114	61459	19283	18716
48 (1219.2)	38277	61502	19284	18717
60 (1524.0)	58827		19285	18718
72 (1828.8)	36113	61503	21131	58820
96 (2438.4)	38278	61504	19286	58821
144 (3657.6)	34200			

56524 Coolant Mister

Supplies Cooling Mist Directly to the Cutting Edge through the Super Drill or Allied Machine & Tool RCA (Rotary Coolant Adapter)

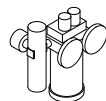

59804 New-Lube Coolant, 1 gallon

Super Drill

- 57629 Kit A1 1.968 - 2.165 inches (50 - 55 mm) #4 Morse taper
- 57647 Kit A2 2.165 - 2.559 inches (55 - 65 mm) #4 Morse taper
- 57652 Kit B 2.559 - 3.149 inches (65 - 80 mm) #4 Morse taper
- 57661 Kit C 3.149 - 3.937 inches (80 - 100 mm) #4 Morse taper
- 57667 Kit D 3.937 - 4.724 inches (100 - 120 mm) #4 Morse taper
- 57692 SBG Sharpening Fixture

See the CLIMAX Drilling & Blind Hole Boring supplement for a complete listing of insert, drill components and accessories.

Criterion

- 59767 CB-203D 3 inch (76.2 mm) diameter boring head kit
- 59768 CB-204D 4 inch (101.6 mm) diameter boring head kit

NOTE: Drawings are for reference only, are not to scale, and may not represent actual product.

Facing and Grooving Heads for your BB5000

Climax PN	31412	30051	30044	35858	36936	36954	45040	60301
Item Name	Adjustable Range Facing Heads			Facing & Grooving Heads			Heavy Duty Facing Head	
Bar Dia.	1-¼ (31.8)	2.0 (50.8)	2-¼ (57.2)	1-¾ (44.5)	2-¼ (57.2)	2-¼ (57.2)	2-¼ (57.2)	2.0 (50.8 mm)
Swing Dia.	6.6 - 9.4 (167.6 - 238.8)	9.1 - 22.2 (231.1 - 563.9)	10.0 - 18.6 (254 - 472.4)	13.5 (342.9)	13.5 (342.9)	20.3 (515.6)	20.1 - 25.3 (510.5 - 642.6)	
Facing Dia.	2.1 - 8.8 (53.3 - 223.5)	2.5 - 18 (63.5 - 457.2)	2.5 - 18 (63.5 - 457.2)	2.5 - 12 (63.5 - 304.8)	2.5 - 12 (63.5 - 304.8)	2.5 - 19.0 (63.5 - 482)	2.25 - 24.0 (57.2 - 609.6)	
Grooving Dia.	n/a	n/a	n/a	3.5 - 12 (88.9 - 304.8)	4.0 - 12.0 (101.6 - 304.8)	4.0 - 19.0 (101.6 - 482.6)	3.3 - 24.0 (83.8 - 609.6)	

No. Description

Bore Measuring Tool

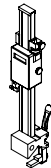

Features a fine adjustment feature which allows precision bore measurement and sets tool bit height while the bar is still mounted in the work piece.

70645 Mounts on any bar from 1-¼ to 2-¼ inches (31.8 to 57.2 mm) in diameter. Measures up to 12 inches (304.8 mm) diameter bores.

67487 Mounts on any bar from 1-¼ to 2-¼ inches (31.8 to 57.2 mm) in diameter. Measures up to 24 inches (609.6 mm) diameter bores.

Magnetic Back Dial Indicator

Top quality travel dial indicator with magnetic back, made by Starrett® for CLIMAX. Useful for many things including:



- Precisely setting depth of cut.
- Measuring and setting boring bar travel when cutting to a shoulder.
- Facing operations, precision alignment of boring bar to larger bores.

45396 0 - .500 inch range (.001 increment) - white face

45397 0 - 10 mm range (.01 mm increment) - yellow face

Digital Bore Measuring Caliper



Get an accurate reading of the bore without removing the bar. Features locking, micro-adjust slide.

61707 Measures up to 10 inches (254.0 mm) ID/OD

63330 Measures up to 24 inches (609.6 mm) ID/OD

Boring Heads

Boring heads may be positioned anywhere along the bar. Split body allows attachment without moving the bar. Boring heads to fit 2.0 inch (50.8 mm) diameter bars also available.



11817 HSS-inch boring head set (included in Base Unit 49003) Has (5) boring heads to bore 4.5 - 12 inch diameter



34565 HSS-metric boring head set (included in Base Unit 49004) Has five boring heads to bore 114.3 - 304.3 mm diameter. Uses standard 10 mm & 12 mm square cutter.



16161 Boring head set Has boring hub and boring head arms to bore 12 - 24 inch (304.8 - 609.6 mm) diameter.

Tool Kits

Complete set of tools for the boring bar (included in base unit)

28784 Tool Kit (Inch)

34580 Tool Kit (Metric)

Tool Holder Kit

56275 Tool Holder Kit Complete set (L/R/neutral) with five 80 degree diamond inserts with ½ inch square shank.



NOTE: Drawings are for reference only, are not to scale, and may not represent actual product.

No. Description

Tool Bits

HSS standard tool bits (inch)

31866 ½ inch x 1.0 inch LH 15° lead*

31857 ½ inch x 1.0 inch LH 0° lead*

31867 ½ inch x 1.8 inches LH 15° lead*

31858 ½ inch x 1.8 inches LH 0° lead*

32344 ½ inch x 2.5 inches LH 15° lead*

32342 ½ inch x 2.5 inches LH 0° lead*

31868 ½ inch x 4.0 inches LH 15° lead

31859 ½ inch x 4.0 inches LH 0° lead

25710 ½ inch x 2.5 inches LH & RH double-ended

HSS Tool Bits (Metric)

34574 HSS 12 mm x 1.0 inches (25.4 mm) LH 0° lead**

34578 HSS 12 mm x 1.8 inches (45.7 mm) LH 15° lead**

34579 HSS 12 mm x 1.0 inches (25.4 mm) LH 0° lead**

34573 HSS 12 mm x 1.8 inches (45.7 mm) LH 0° lead**

34577 HSS 12 mm x 2.5 inches (63.5 mm) LH 15° lead**

34572 HSS 12 mm x 2.5 inches (63.5 mm) LH 0° lead**

34576 HSS 12 mm x 4.0 inches (101.6 mm) LH 15° lead

34571 HSS 12 mm x 4.0 inches (101.6 mm) LH 0° lead

Alternative Tool Bits

31848 HSS ½ inch x 1.0 inch RH 15° lead

31830 HSS ½ inch x 1.0 inch RH 0° lead

32103 HSS ½ inch x 1.0 inch RH 0° lead side cutting

32114 HSS ½ inch x 1.0 inch LH 0° lead side cutting

31849 HSS ½ inch x 1.8 inch RH 15° lead

31831 HSS ½ inch x 1.8 inch RH 0° lead

32104 HSS ½ inch x 1.8 inch RH 0° lead side cutting

32115 HSS ½ inch x 1.8 inch LH 0° lead side cutting

32345 HSS ½ inch x 2.5 inch RH 15° lead

32343 HSS ½ inch x 2.5 inch RH 0° lead

32341 HSS ½ inch x 2.5 inch RH 0° lead side cutting

32340 HSS ½ inch x 2.5 inch LH 0° lead side cutting

31850 HSS ½ inch x 4.0 inch RH 15° lead double-ended

31841 HSS ½ inch x 4.0 inch RH 0° lead double-ended

32105 HSS ½ inch x 4.0 inch RH 0° lead side cutting

32116 HSS ½ inch x 4.0 inch LH 0° lead side cutting

34348 HSS ½ inch x 4.0 inch LH 15° lead double-ended

Twin Leadscrew Facing Head Tool Bits

31868 HSS ½ inch x 4.0 inch LH 15° lead

31917 Carbide ½ inch x 3.5 inch LH 15° lead

Facing/Grooving Tool Facing Bits

31849 HSS ½ inch x 1.8 inch RH 15° lead

31831 HSS ½ inch x 1.8 inch RH 0° lead

36370 1 each of the 15° lead and 0° lead bits

Facing/Grooving Tool Facing Bits

35948 HSS LH grooving 0.12 inches wide, 15° lead top rake

37766 HSS LH grooving 0.12 inches wide, 0° lead top rake

35949 HSS LH grooving 0.56 inches wide, 15° lead top rake

37767 HSS LH grooving 0.56 inches wide, 0° lead top rake

* Included in Tool Kit 28784

** Included in Tool Kit 34580

Further customize your BB5000 Boring Machine with these boring bar options. Order separately.
(customized bars available upon request)

- All bars are made of 1045 S-CPO chrome-plated steel.
- Standard bars available in 2 foot (609.6 mm) increments up to 24 feet (7.3 meters) long, with various hole spacing.
- After machining, bars are straightened to within 0.001 inches per foot (0.025 per 304.8 mm).
- Bars come packaged in a fitted steel container with quick-release latches.
- First hole is 1 inch (25.4 mm) from the end of the bar, for all bar lengths.
- Morse taper and straight shank holders available upon request.

2.0 inch (50.8 mm) diameter bars available upon request. 6 inch hole spacing is available on longer bars upon request.

Bars with Inch Tooling

Holes spaced every 6 inches (152.4 mm)	Holes spaced every 10 inches (254.0 mm)	Bar Diameter	Bar Length	Hole Size
39309	34626	2-1/4 inch (57.2 mm)	48 inches (1219.2 mm)	1/2 inch
39310	34627	2-1/4 inch (57.2 mm)	72 inches (1828.8 mm)	1/2 inch
41552	34628	2-1/4 inch (57.2 mm)	96 inches (2438.4 mm)	1/2 inch
43728	34629	2-1/4 inch (57.2 mm)	120 inches (3048.0 mm)	1/2 inch
43729	34630	2-1/4 inch (57.2 mm)	144 inches (3657.6 mm)	1/2 inch
39308	37337	1-1/4 inch (31.8 mm)	48 inches (1219.2 mm)	3/8 inch
43693	37338	1-1/4 inch (31.8 mm)	72 inches (1828.8 mm)	3/8 inch
39447	37339	1-1/4 inch (31.8 mm)	96 inches (2438.4 mm)	3/8 inch
n/a	37340	1-1/4 inch (31.8 mm)	120 inches (3048.0 mm)	3/8 inch
n/a	37341	1-1/4 inch (31.8 mm)	144 inches (3657.6 mm)	3/8 inch
43311	43318	1-3/4 inch (44.5 mm)	48 inches (1219.2 mm)	1/2 inch
43313	43320	1-3/4 inch (44.5 mm)	72 inches (1828.8 mm)	1/2 inch
43314	43321	1-3/4 inch (44.5 mm)	96 inches (2438.4 mm)	1/2 inch
43315	43322	1-3/4 inch (44.5 mm)	120 inches (3048.0 mm)	1/2 inch
43316	43323	1-3/4 inch (44.5 mm)	144 inches (3657.6 mm)	1/2 inch

Bars with Metric Tooling

Holes spaced every 6 inches (152.4 mm)	Holes spaced every 10 inches (254.0 mm)	Bar Diameter	Bar Length	Hole Size
43740	34635	2-1/4 inch (57.2 mm)	48 inches (1219.2 mm)	12 mm
43741	34636	2-1/4 inch (57.2 mm)	72 inches (1828.8 mm)	12 mm
43742	34637	2-1/4 inch (57.2 mm)	96 inches (2438.4 mm)	12 mm
43743	34638	2-1/4 inch (57.2 mm)	120 inches (3048.0 mm)	12 mm
43744	34639	2-1/4 inch (57.2 mm)	144 inches (3657.6 mm)	12 mm
43687	37327	1-1/4 inch (31.8 mm)	48 inches (1219.2 mm)	10 mm
43686	37328	1-1/4 inch (31.8 mm)	72 inches (1828.8 mm)	10 mm
43685	37329	1-1/4 inch (31.8 mm)	96 inches (2438.4 mm)	10 mm
n/a	37330	1-1/4 inch (31.8 mm)	120 inches (3048.0 mm)	10 mm
n/a	37331	1-1/4 inch (31.8 mm)	144 inches (3657.6 mm)	10 mm
43298	43305	1-3/4 inch (44.5 mm)	48 inches (1219.2 mm)	12 mm
43307	43300	1-3/4 inch (44.5 mm)	72 inches (1828.8 mm)	12 mm
43301	43308	1-3/4 inch (44.5 mm)	96 inches (2438.4 mm)	12 mm
43302	43309	1-3/4 inch (44.5 mm)	120 inches (3048.0 mm)	12 mm
43303	43310	1-3/4 inch (44.5 mm)	144 inches (3657.6 mm)	12 mm

A Wide Variety of Applications

Do you need to put the axial feed unit on one end of the bar and the rotational drive on the other? No problem... all you need to do is use the leadscrew block clamped or tack welded to the work piece. In fact, just about any arrangement of components can be used as long as you maintain rigidity by placing bearing supports as close as possible to the holes to be bored. Need to align and multiple holes? Just use a long bar and weld a bearing bracket at each hole for support or use optical alignment for easy & precise setup over long distances. Modular components let you use the machine in a wide variety of combinations.

The BB5000 is widely used by these industries:

- Construction
- Mining
- Power Generation
- Ship building
- Transportation
- Petrochemical
- Pulp and paper
- Steel and aluminum

Typical applications:

- Heavy equipment repair
- Stern tube boring
- Wicket gate repair on dams
- Bridge building/re-building
- Turbine coupling boring
- Engine block repair
- Bearing seat repair
- Press repair
- Valve body boring
- Pump body boring
- Large fab bore alignment



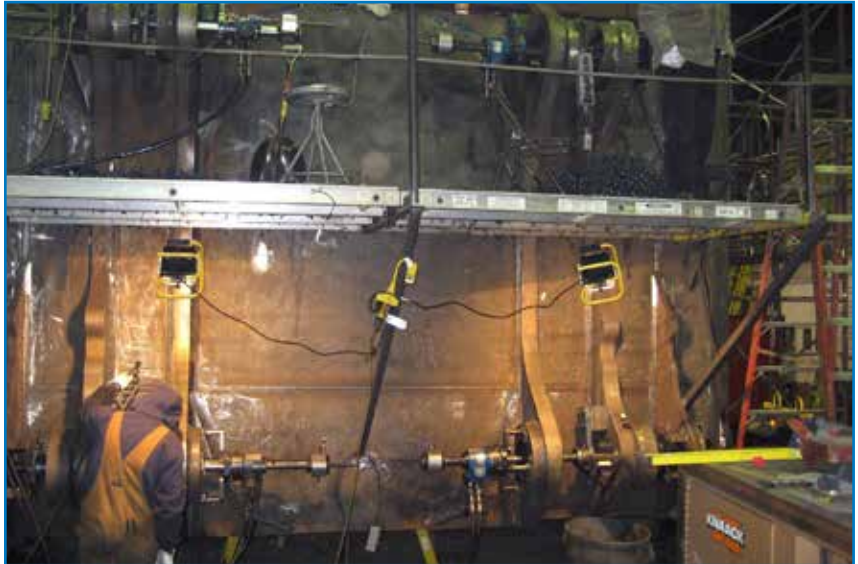

Typical applications:

Whether it's conventional boring, line boring, drilling, facing or grooving, the CLIMAX BB5000 has you covered. With versatile setup & machining options, it's the machine you need to get all your toughest jobs done when and where you need it. Typical applications illustrated below.

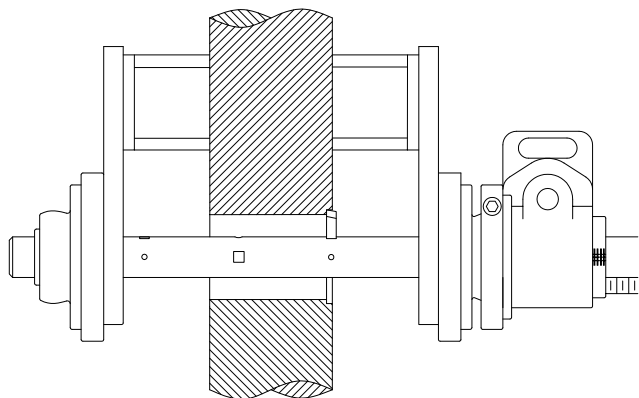

Conventional Boring

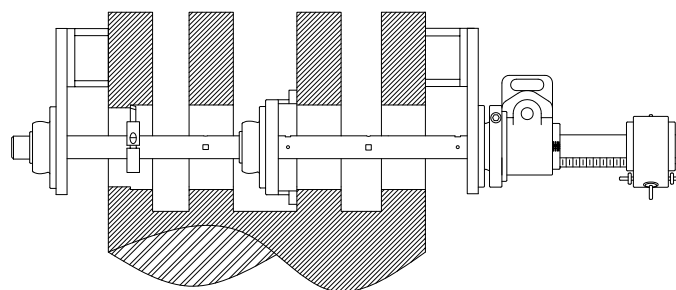

Line Boring

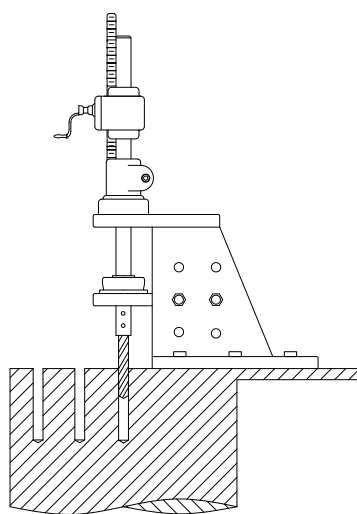

Drilling

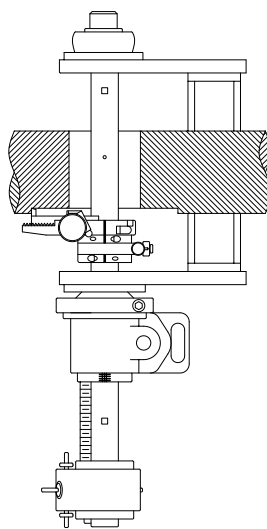

Facing

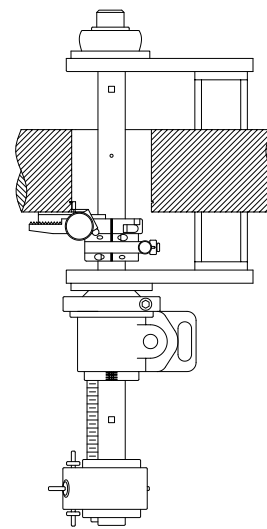

Grooving

NOTE: Drawings are for reference only, are not to scale, and may not represent actual product.

CLIMAX has been teaching the fundamentals and finer points of portable machine tool operation for more than 50 years.

Whether it's a regularly scheduled course at one of our seven Global Training Centers or a custom curriculum conducted with your team, at your facility, your technicians will benefit from courses developed by the most experienced and respected professionals in the business.

Regularly scheduled courses in basic and advanced tool operation are available. A vast majority of every program is devoted to hands-on activities, skills development, and OEM Certification covering the following subject matters: operator safety, tool component review, setup and mounting, standard and advanced operational techniques, overview of cutting tools and recommended usage, and maintenance procedures.



Training is available at the following seven Global Training Centers:

- Portland, Oregon
- Houston, Texas
- Gonzales, Louisiana
- Wadsworth, Ohio
- Manchester, United Kingdom
- Düren, Germany
- Dubai, United Arab Emirates

Call us today to schedule training for your team!



CLIMAX GLOBAL LOCATIONS

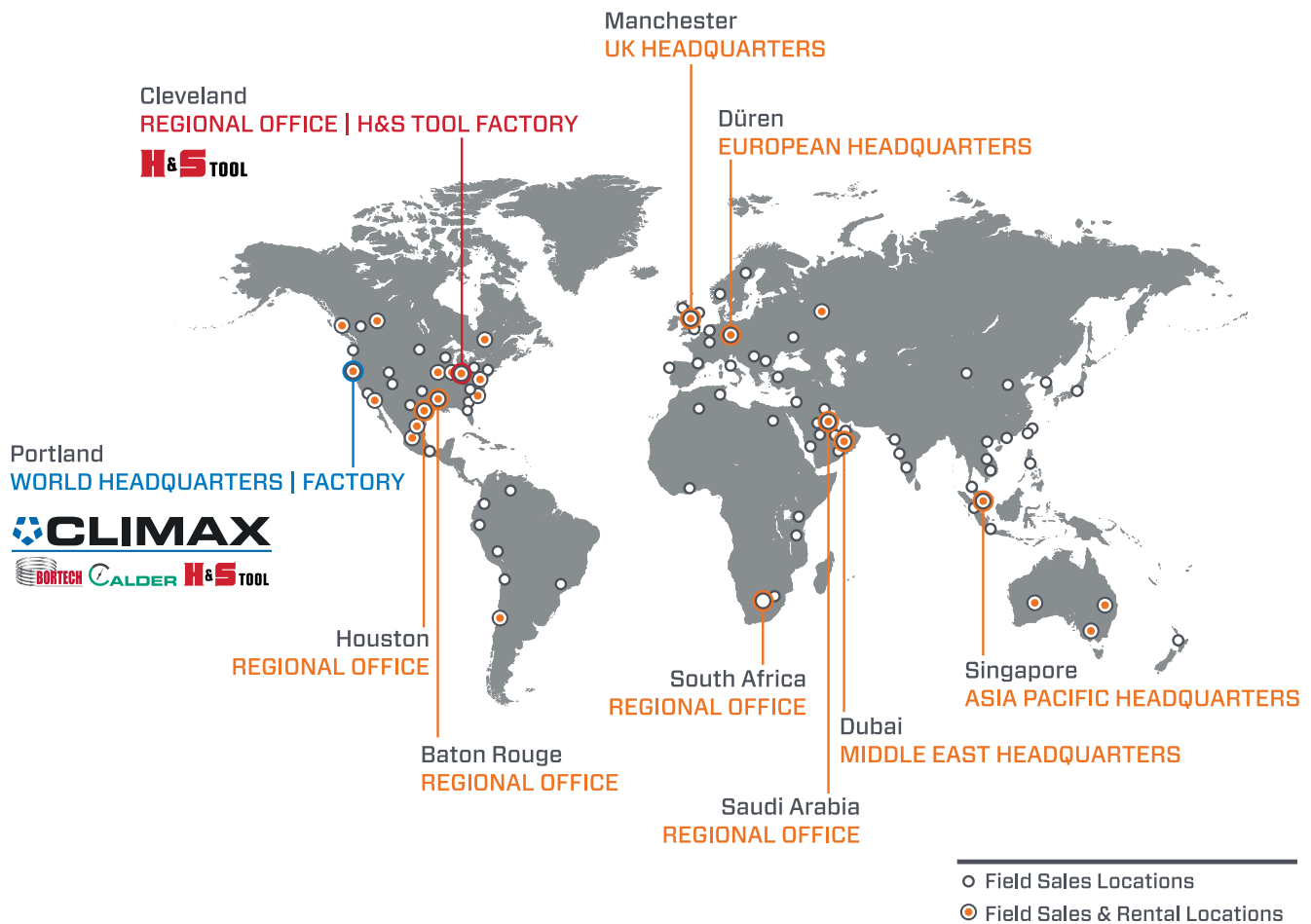

Call CLIMAX for:

RENTALS

With 20+ worldwide rental depot locations, you are never far away from a CLIMAX tool.

ON-SITE TRAINING

If you need training or on-site consultation, we're famous for it!

CUSTOM PROJECTS

Custom turn-key system design services from the most experienced engineers and portable machining and welding experts!

Connect with us:    

World Headquarters

CLIMAX | BORTECH | CALDER Factory
Address: 2712 E. 2nd St, Newberg, Oregon 97132
Tel: +1 503 538 2185
Fax: +1 503 538 7600
Email: info@cpmt.com

Regional Office - Cleveland

H&S TOOL Factory
Address: 715 Weber Dr., Wadsworth, Ohio 44281
Tel: +1 330 336 4550
Email: info@hstool.com

Asia Pacific

Address: 308 Tanglin Rd #02-01, Singapore 247974
Tel: +65 6801 0662
Fax: +65 6801 0699
Email: ClimaxAsia@cpmt.com

European

Address: Am Langen Graben 8, 52353 Düren, Germany
Tel: (+49) (0) 2421 9177 0
Fax: (+49) (0) 2421 9177 29
Email: ClimaxEurope@cpmt.com

Middle East

Address: Warehouse #5, Plot: 369 272, Um Sequim Road, Dubai, UAE
Tel: +971 4 321 0328
Email: ClimaxUAE@cpmt.com

United Kingdom

Address: Unit 7 Castlehill Industrial Estate, Bredbury Industrial Park, Horsfield Way, Stockport SK6 2SU
Tel: +44 (0) 161 406 1720
Email: ClimaxUK@cpmt.com