

Get buckets and loaders back to work with effective on-site repairs.

If you have ever repaired worn hinge points on loader arms or buckets, you know how difficult it is to cut off the worn area and try to weld on new hinge points while keeping everything lined up. A better way is to use the CLIMAX Model BB3000 Portable Line Boring Machine. If the holes are not badly damaged, you can simply weld them up, attach the BB3000 Line Boring Machine, and re-bore them to original dimensions. If the hinge points are so damaged that the entire area needs to be replaced, weld on new sections with slightly undersized holes, then quickly re-bore them to original dimensions while keeping everything in proper alignment.



Boring Capacity

- Bore from 1½ - 5 inches (38.1 - 127.0 mm) in diameter, using the bar and tool head.
- The 1¼ inch (31.75 mm) diameter bar is available in almost any length in 1 foot (304.8 mm) increments.
- Holes are positioned at 6 or 10 inch (152.4 or 254.0 mm) intervals along the bar to hold ⅜ inch square tool bits in the SAE inch version, and 10 mm square tool bits in the metric version.
- The clamp-on tool head covers the ¾ - 5 inch (76.2 - 127.0 mm) diameter range.

Powerful

- 1.0 Hp (0.74 kW), universal type motor drives a 7.5:1 reduction gear box; produces up to 90 ft-lbs (122 N•m) of torque at the bar.
- Two-speed motor has bar speeds ranging from 80 - 150 RPM for 120 VAC, and 68 - 120 RPM for 230 VAC, no load, free speed rpm; 2 - 2.2 amps.
- Metal removal rate of up to 1 cubic inch/min (16.4 cm³/min) in C1018 steel.

Compact Design

- The rotational drive extends only 19 inches (482.6 mm) out from the mounting bracket and 14 inches

(355.6 mm) from the bar to the top of the motor. The rotational drive can be mounted with the motor in any position around the bar if clearance is a problem.

- Rotational drive with feed rack and anti-torque scissors weighs only 35 lbs. (15.9 kg).

Automatic Power Feed

- Infinitely variable, reversible power feed has a 10 inch (254.0 mm) stroke. An automatic feed stop mechanism disengages the feed at the end of the 10 inch stroke.
- Feed rate is from 0 - 0.018 inches (0 - 0.46 mm) per revolution.

Operating Ranges	
Boring Bar Diameter	1.25 inches (31.8 mm)
Boring Diameter	1.5 - 5 inches (38.1 - 127 mm)
Boring Stroke, Max	10 inches (254 mm)
Power Options	
Pneumatic	0.6 Hp (0.45 kW)
2-Speed Electric 120 VAC: low - up to 80 free speed bar RPM; high - up to 150 free speed bar RPM 230 VAC: low - up to 68 free speed bar RPM; high - up to 120 free speed bar RPM	1.0 Hp (0.74 kW)
Mounting Options	Double Arm, Universal
Rotational Drive Unit	7.5:1 gear ratio reduction
Set-Up Cones	1.5 - 5 inches (38.1 - 127.0 mm)
Feed Type	Mechanical
Feed Rate per revolution	0 - 0.018 inches/rev. (0 - 0.46 mm/rev.)
Measures	
Typical Machine Ship Weight (Typical machine with double arm mounts, set-up cones & electric motor)	240 lbs (109 kg)
Approximate Boring Bar Ship Weight (Standard 1-1/4 inch (31.8 mm) bar, 72 inches (1828.8 mm) long. Includes metal shipping container.)	50 lbs (22.7 kg)
<i>Typical Shipping Dimensions (Shipped in 2 containers)</i>	
Machine W, D, H	34 x 20 x 20 inches (864 x 508 x 508 mm)
Bar 72 inch (1828.8 mm) W, D, H	75 x 7 x 7 inches (1905 x 178 x 178 mm)

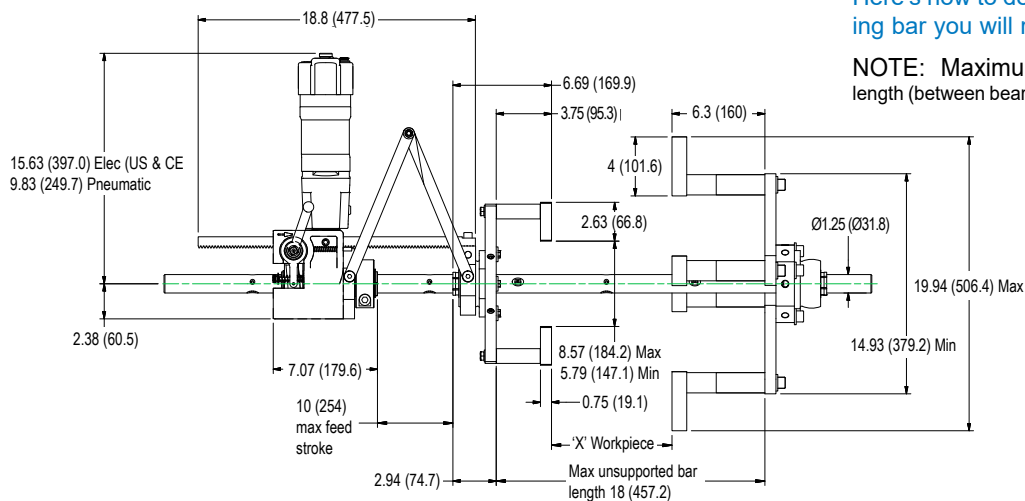

Here's how to determine the length of the boring bar you will require

NOTE: Maximum recommended unsupported bar length (between bearing supports) is 18 inches (457.2 mm)

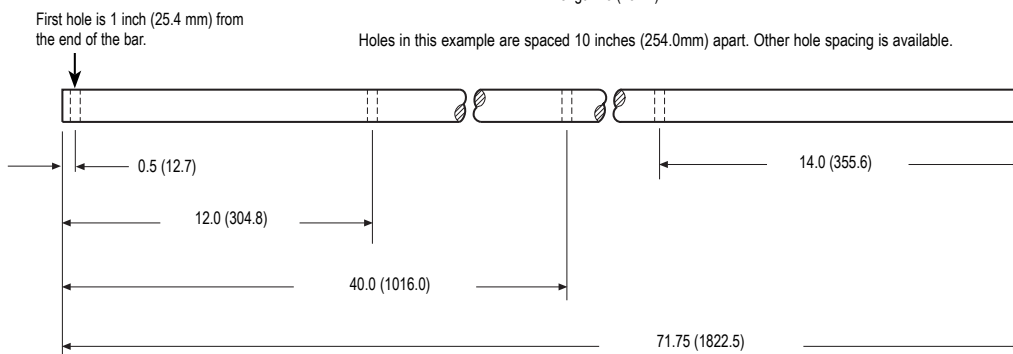

Sample boring bar broached hole locations (72 inch (1828.8 mm) bar only)

All dimensions should be considered reference. Contact your CLIMAX Representative for precision dimensions. Specifications are subject to change without notice. There are no systems or components on this machine that are capable of producing hazardous EMC, UV or other radiation hazards. The machine does not use lasers nor does it create hazardous materials such as gasses or dust.

Dimensions in Inch (mm)

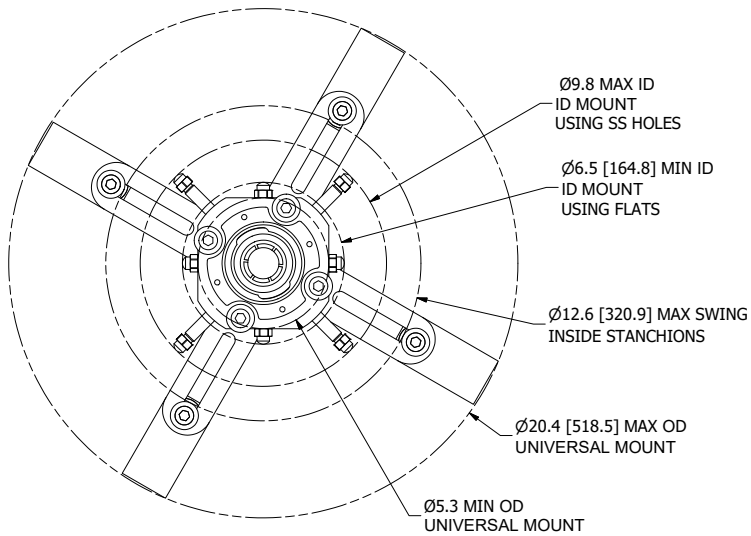

Universal bearing mount assembly (overhead view)

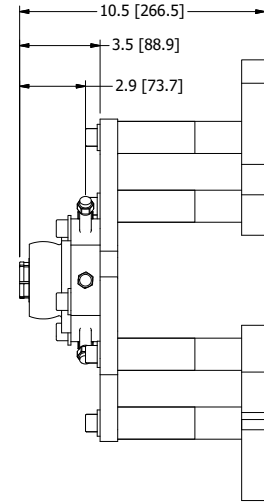

Universal bearing mount assembly (side view)

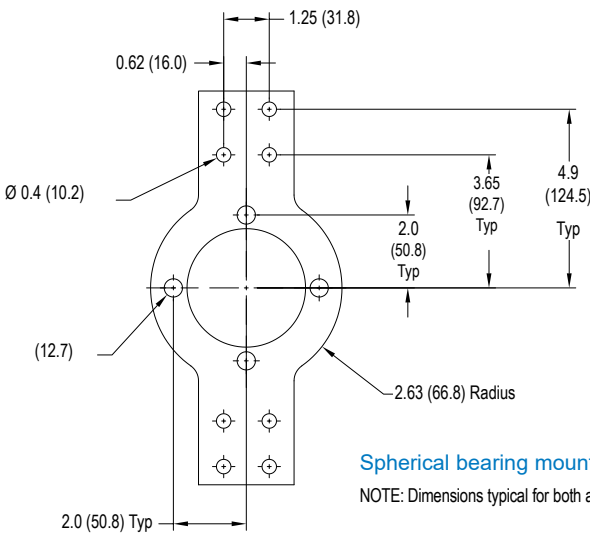

Spherical bearing mount assembly

NOTE: Dimensions typical for both arms

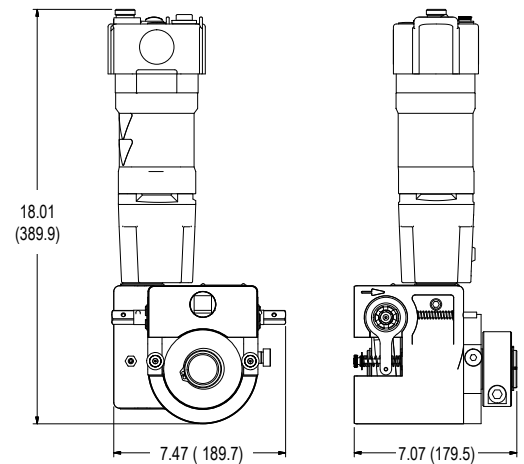

Rotational drive assembly

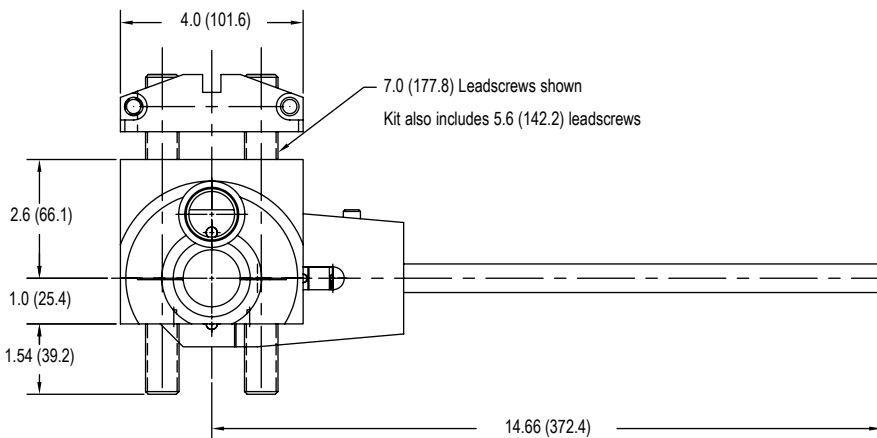

Facing Head, overhead view

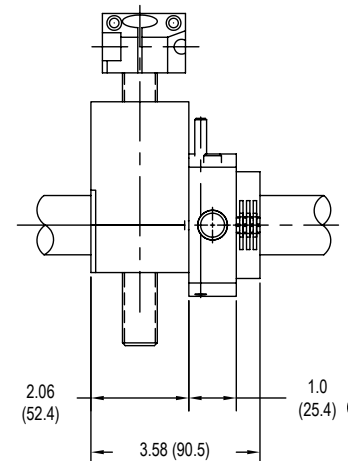

Facing Head, side view and side view (right)

Configure your BB3000 in 5 easy steps:

To configure your BB3000 Boring Machine:

- 1 Select a Base Unit
- 2 Select a Boring Bar
- 3 Select a Drive Motor Option
- 4 Select Setup Cones
- 5 Select a Mounting Option

To generate the correct part number for the boring machine you require, simply select the part number needed in each step, and contact your CLIMAX representative.

The Base Unit includes the RDU, tool kit, tool head, packaging, and instruction manual. The unit comes packed in a durable metal container.

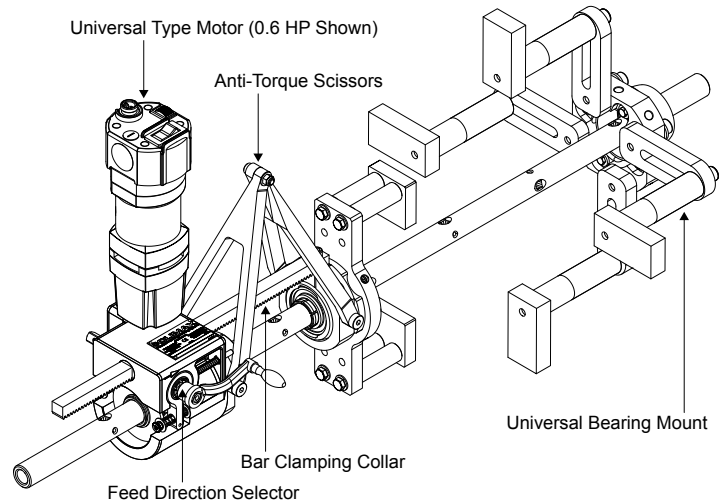

1 Base Unit

Standard Inch Unit	37453
Standard Metric Unit	37493

2 Boring Bar, 1-¼ inch dia.

Holes spaced every 6 inches (152.4 mm)

48 inch, 3/8 inch holes	43657
72 inch, 3/8 inch holes	43658
96 inch, 3/8 inch holes	43659
48 inch (1219.2 mm), 10 mm holes	43640
72 inch (1828.8 mm), 10 mm holes	43641
96 inch (2438.4 mm), 10 mm holes	43642

* Multiple units may be ordered.

Boring Bar, 1-¼ inch dia.

Holes spaced every 10 inches (254 mm)

48 inch, 3/8 inch holes	43651
72 inch, 3/8 inch holes	43652
96 inch, 3/8 inch holes	43653
48 inch (1219.2 mm), 10 mm holes	43634
72 inch (1828.8 mm), 10 mm holes	43636
96 inch (2438.4 mm), 10 mm holes	43629

* Multiple units may be ordered.

3 Drive Motor

Electric, 120 VAC Speed Control, 80/150 bar rpm, 2 speed for 1 Hp motors	37459
Electric, 230 VAC Speed Control, 68/120 bar rpm, 2 speed for 1 Hp motors	37460
Pneumatic, 175 rpm for 0.6 Hp motor (includes air conditioning unit)	37085

* Multiple units may be ordered.

4 Setup Cones

Small: 1½ – 3¼ inch (38.1 – 82.6 mm) dia.	26263
Large: 3¼ – 5 inch (82.6 – 127.0 mm) dia.	26264
Full Set: 1½ – 5 inch (38.1 – 127.0 mm) dia.	27803

5 Mounting Option

Double arm mount	24756
Universal mount	36961
ID mounting kit	37621

* Multiple units may be ordered.



Further customize your BB3000 Boring Machine with these main boring bar options.
Order separately (special customized bars available upon request)

- All bars are 1-¼ inch (31.8 mm) in diameter, and made of 1045 S-CPO chrome-plated steel.
- After machining, bars are straightened.
- Bars come packaged in a fitted steel container with quick-release latches.
- First hole is 1 inch from the end of the bar, for all bar lengths and hole spacing.

Part number	Bar length		Hole size	Hole spacing																																															
43650	36 inches	914.4 mm	3/8 inch	10 inches	254.0 mm																																														
43651	48 inches	1219.2 mm	3/8 inch	10 inches	254.0 mm																																														
43652	72 inches	1828.8 mm	3/8 inch	10 inches	254.0 mm																																														
43653	96 inches	2438.4 mm	3/8 inch	10 inches	254.0 mm																																														
43654	120 inches	3048.0 mm	3/8 inch	10 inches	254.0 mm																																														
43655	144 inches	3657.6 mm	3/8 inch	10 inches	254.0 mm																																														
43633	36 inches	914.4 mm	10 mm	10 inches	254.0 mm																																														
43634	48 inches	1219.2 mm	10 mm	10 inches	254.0 mm																																														
43636	72 inches	1828.8 mm	10 mm	10 inches	254.0 mm																																														
43629	96 inches	2438.4 mm	10 mm	10 inches	254.0 mm																																														
43637	120 inches	3048.0 mm	10 mm	10 inches	254.0 mm																																														
43638	144 inches	3657.6 mm	10 mm </tr <tr> <td>43656</td> <td>36 inches</td> <td>914.4 mm</td> <td>3/8 inch</td> <td>6 inches</td> <td>152.4 mm</td> </tr> <tr> <td>43657</td> <td>48 inches</td> <td>1219.2 mm</td> <td>3/8 inch</td> <td>6 inches</td> <td>152.4 mm</td> </tr> <tr> <td>43658</td> <td>72 inches</td> <td>1828.8 mm</td> <td>3/8 inch</td> <td>6 inches</td> <td>152.4 mm</td> </tr> <tr> <td>43659</td> <td>96 inches</td> <td>2438.4 mm</td> <td>3/8 inch</td> <td>6 inches</td> <td>152.4 mm</td> </tr> <tr> <td>43639</td> <td>36 inches</td> <td>914.4 mm</td> <td>10 mm</td> <td>6 inches</td> <td>152.4 mm</td> </tr> <tr> <td>43640</td> <td>48 inches</td> <td>1219.2 mm</td> <td>10 mm</td> <td>6 inches</td> <td>152.4 mm</td> </tr> <tr> <td>43641</td> <td>72 inches</td> <td>1828.8 mm</td> <td>10 mm</td> <td>6 inches</td> <td>152.4 mm</td> </tr> <tr> <td>43642</td> <td>96 inches</td> <td>2438.4 mm</td> <td>10 mm</td> <td>6 inches</td> <td>152.4 mm</td> </tr>	43656	36 inches	914.4 mm	3/8 inch	6 inches	152.4 mm	43657	48 inches	1219.2 mm	3/8 inch	6 inches	152.4 mm	43658	72 inches	1828.8 mm	3/8 inch	6 inches	152.4 mm	43659	96 inches	2438.4 mm	3/8 inch	6 inches	152.4 mm	43639	36 inches	914.4 mm	10 mm	6 inches	152.4 mm	43640	48 inches	1219.2 mm	10 mm	6 inches	152.4 mm	43641	72 inches	1828.8 mm	10 mm	6 inches	152.4 mm	43642	96 inches	2438.4 mm	10 mm	6 inches	152.4 mm
43656	36 inches	914.4 mm	3/8 inch	6 inches	152.4 mm																																														
43657	48 inches	1219.2 mm	3/8 inch	6 inches	152.4 mm																																														
43658	72 inches	1828.8 mm	3/8 inch	6 inches	152.4 mm																																														
43659	96 inches	2438.4 mm	3/8 inch	6 inches	152.4 mm																																														
43639	36 inches	914.4 mm	10 mm	6 inches	152.4 mm																																														
43640	48 inches	1219.2 mm	10 mm	6 inches	152.4 mm																																														
43641	72 inches	1828.8 mm	10 mm	6 inches	152.4 mm																																														
43642	96 inches	2438.4 mm	10 mm	6 inches	152.4 mm																																														

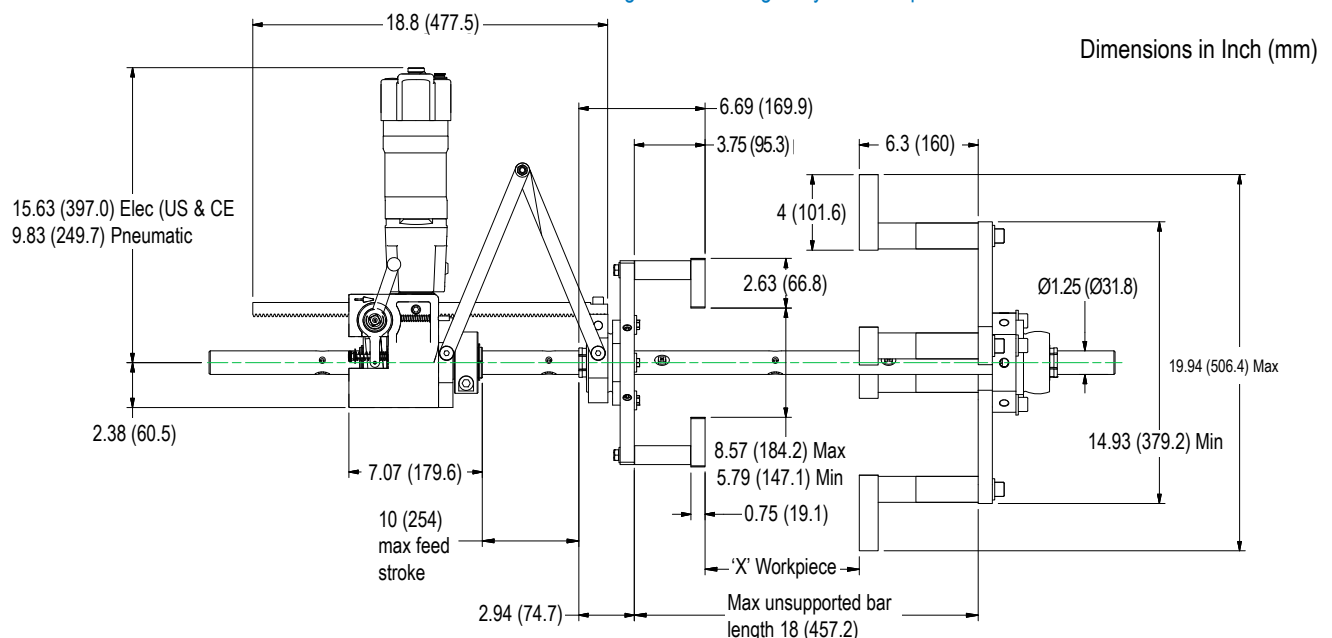
Here's how to determine the length of the boring bar you will require:

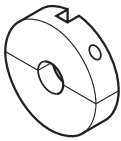
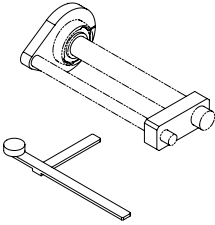
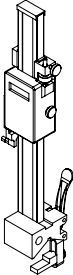
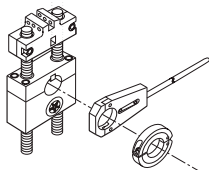

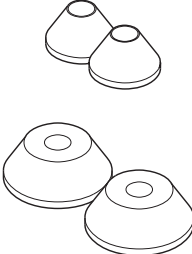
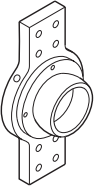
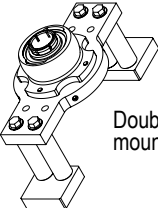
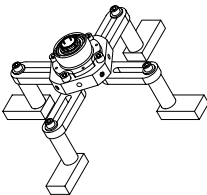
	NO. DESCRIPTION		NO. DESCRIPTION
	<p>Tool Head</p> <p>Tool heads can be positioned anywhere along the bar. Split body allows attachment without moving the bar. Included in Base Units shown on page 5.</p> <p>19449 Inch kit for 3.25 - 5 inch diameters 33713 Metric kit for 82.6 - 127 mm diameters</p>		<p>Automatic Bore Welding Accessories</p> <p>Attach and quickly align the CLIMAX auto bore welders for efficient bore welding.</p> <p>26795 Bore welder interface kit</p> <p>Allows you to attach and quickly align the CLIMAX Auto Bore Welders for efficient bore welding. Includes adapter plate, alignment tool, and spherical bearing removal wrench.</p>
	<p>Tool Kit (not shown)</p> <p>Complete set of tools for the boring machine, included in Base Units shown on page 5.</p> <p>19697 Inch kit 37494 Metric kit</p>		<p>Bore Measuring Tool</p> <p>Features a fine adjustment feature which allows precision bore measurement and sets tool bit height while the bar is still mounted in the work piece.</p> <p>70645 Mounts on any bar from 1-¼ to 2-¼ inches (31.8 to 57.2 mm) in diameter. Measures up to 12 inches (304.8 mm) diameter bores</p> <p>67487 Mounts on any bar from 1-¼ to 2-¼ inches (31.8 to 57.2 mm) in diameter. Measures up to 24 inches (609.6 mm) diameter bores</p>
	<p>Facing Head Assembly</p> <p>Face from 2 - 7 inches (50.8 - 177.8 mm) in diameter, or from 2 - 10 inches (50.8 - 254 mm) with leadscrew set. Bi-directional operation, 0.005 inch/rev (0.127 mm/rev) fixed feed rate.</p> <p>31412 Facing head assembly</p>		<p>Digital Bore Measuring Caliper</p> <p>Get an accurate reading of the bore without removing the bar. Features locking, micro-adjust slide.</p> <p>61707 Measures up to 10 inches (254.0 mm) ID/OD</p> <p>63330 Measures up to 24 inches (609.6 mm) ID/OD</p>
	<p>Set-up Cones</p> <p>Aluminum set-up cones slide onto the bar and into bore holes for quick set-up.</p> <p>26263 Small set-up cone set, aluminum. For 1.5 to 3.25 inch (38.1 to 82.6 mm) diameter bores</p> <p>26264 Large set-up cone set, aluminum. For 3.25 - 5 inch (82.6 - 127.0 mm) diameter bores</p>	<p>Please note: Drawings are for reference only, are not to scale, and may not represent actual product.</p>	
<p>Spherical mount</p>  <p>Double arm mount</p>  <p>Universal mount</p> 	<p>Bearing Mounts</p> <p>Available in double arm and universal styles, our spherical bearing mounts attach directly to the work piece, and accept both the BB3000 rotational drive unit and the mounting bracket for the CLIMAX Auto Bore Welders.</p> <p>26794 Spherical mount (required for all machines made before January, 1993)</p> <p>24756 Double arm mount</p> <p>36961 Universal mount</p> <p>37621 Universal mount ID conversion kit</p>		

A Fast Six-Step Process

Setup of the BB3000 Portable Boring Machine is quick and easy. An experienced operator can set up the machine in most typical two-bore line boring applications in about half an hour (depending on alignment tolerances).

The three main ingredients of the quick setup system are:

- Setup cones to roughly center the bar in the bore.
- Spherical mounts that can be quickly tack-welded in place.
- Quick-mount rotational drive unit, attaches to spherical mount in seconds

1 Slide the bar through the two holes to be bored and roughly center it with the set-up cones. The set-up cones are forced into the bore with the clamp ring jacking screw and locked onto the bar with a set screw.

Elapsed time: 4 minutes.



4 Slide the rotational drive onto the bar until the self-aligning mounting collar is firmly seated on the mounting bracket, and lock it in place with one screw.

Elapsed time: 2 minutes.



2 Slide on spherical mounts with tack weld plates, and tack weld them to the workpiece.

These mounts have spherical bearings so they can be mounted up to 5° out of perpendicular alignment.

Elapsed time: 10 minutes.

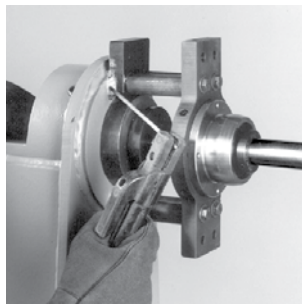

5 With the hand crank, place the rotational drive unit so you have enough stroke for your first boring pass. Tighten the rotational drive clamping collar firmly to lock the rotational drive to the bar.

Elapsed time: 2 minutes.



3 Remove the set-up cones and replace the bar. The set-up cones will adequately center the bar, unless you have very precise tolerances, or need to move the center line of the bore slightly. Final centering adjustments are made with the jacking screws.

Elapsed time: 5 minutes.

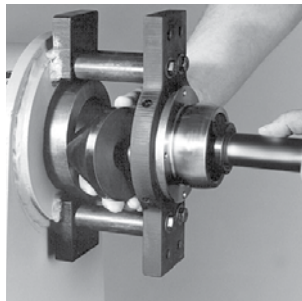

6 Insert a properly ground tool bit into the tool hole in the bar, adjust for depth of cut, and lock in place with the set screw.

Elapsed time: 4 minutes.

Setup is complete, you are ready to begin the first pass.

Total elapsed time:
27 minutes.

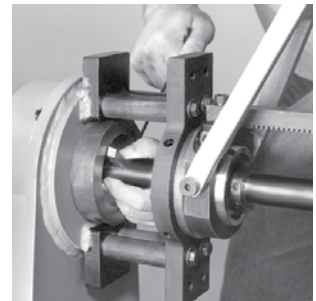

OEM OPERATIONAL TRAINING

Backed by Over 50 Years of Experience

CLIMAX pioneered the concept of portable machine tools in 1964. Since that time, CLIMAX has grown to become the world's largest provider of innovative on-site machining solutions.

Professional, Experienced Instructors

All training programs are taught by experienced OEM CLIMAX trainers. Your instructor will provide valuable information on operator safety, tool set-up, mounting, and operation that will help you complete your on-site machining tasks quickly and to the highest quality standards.

Sign up today for training at one of our seven Global CLIMAX training centers.

- Portland, Oregon
- Houston, Texas
- Baton Rouge, Louisiana
- Cleveland, Ohio
- Manchester, United Kingdom
- Düren, Germany
- Dubai, United Arab Emirates



Call CLIMAX for:

RENTALS

On selected models. With 20+ worldwide rental depot locations, you are never far away from CLIMAX.

OEM TRAINING

If you need training or on-site consultation, we're famous for it!



SPARES, REPAIR & MAINTENANCE

Call us for anything you need to keep your system running in top condition.

CUSTOM PROJECTS

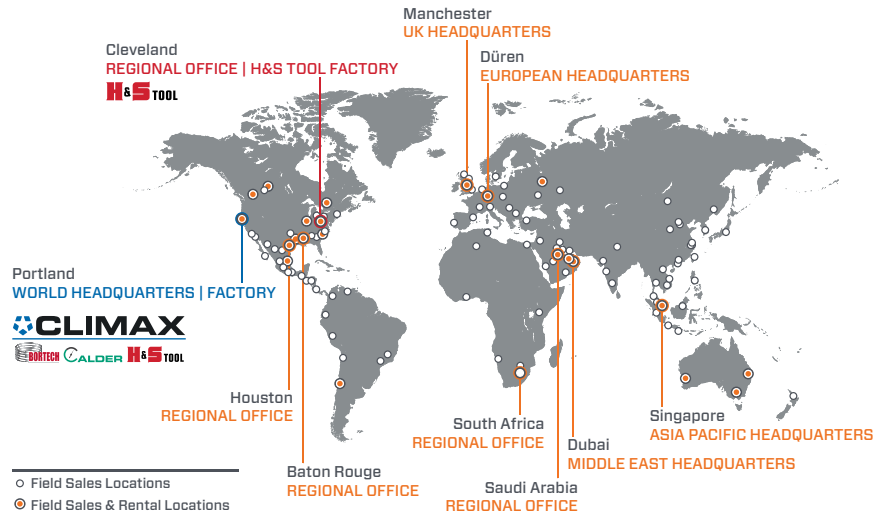
Custom turn-key system design services from the most experienced engineers in the business!



Follow us on:   

World Headquarters

CLIMAX | BORTECH | CALDER Factory
Address: 2712 E. 2nd St, Newberg, Oregon 97132
Tel: +1 503 538 2185
Fax: +1 503 538 7600
Email: info@cpmt.com

Regional Office - Cleveland

H&S TOOL Factory
Address: 715 Weber Dr., Wadsworth, Ohio 44281
Tel: +1 330 336 4550
Email: info@hstool.com

Asia Pacific

Address: 308 Tanglin Rd #02-01, Singapore 247974
Tel: +65 6801 0662
Fax: +65 6801 0699
Email: ClimaxAsia@cpmt.com

European

Address: Am Langen Graben 8, 52353 Düren, Germany
Tel: (+49) (0) 2421 9177 0
Fax: (+49) (0) 2421 9177 29
Email: ClimaxEurope@cpmt.com

Middle East

Address: Warehouse #5, Plot: 369 272, Um Sequim Road, Dubai, UAE
Tel: +971 4 321 0328
Email: ClimaxUAE@cpmt.com

United Kingdom

Address: Unit 7 Castlehill Industrial Estate, Bredbury Industrial Park, Horsfield Way, Stockport SK6 2SU
Tel: +44 (0) 161 406 1720
Email: ClimaxUK@cpmt.com